

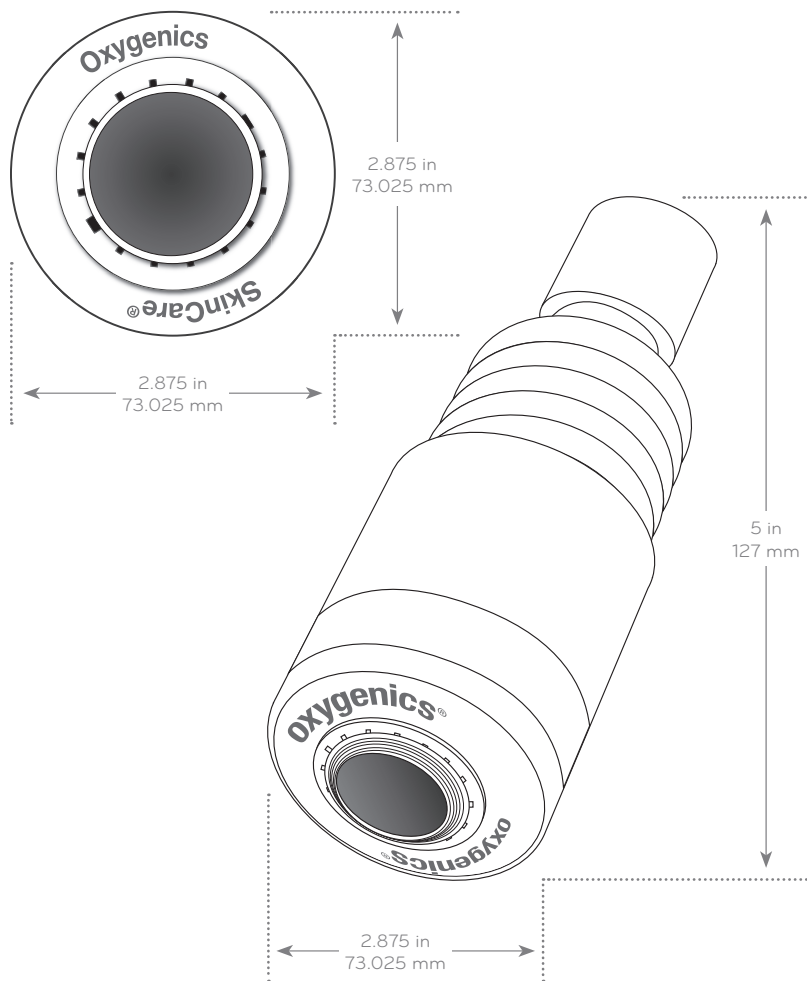

Submitted Model No.: \_\_\_\_\_

Specific Features: \_\_\_\_\_



**PRODUCT SPECIFICATIONS:**

- Dimensions:** 2.875" x 5" x 2.875"
- Weight:** 0.65 lb.
- Max Flow Rate:** 1.5 GPM, 2.0 GPM
- Available Finishes:** Chrome

**SETTINGS:**



Oxygenics

**FEATURES:**

- + **Powerful Oxygenics engine amplifies water pressure**, turning weak showers into powerful showers in just minutes.
- + Reduces water usage and energy costs, **saving up to \$130+ per year.**
- + Technology **strengthens spray and increases oxygen content.**
- + **Quality construction** and non-stick internal materials deliver continuous performance.
- + **Includes a lifetime warranty** never to clog or fail.
- + **Used in spas and resorts** around the world.

**WHAT'S INCLUDED:**

- + Fixed Shower + Plumber's Tape

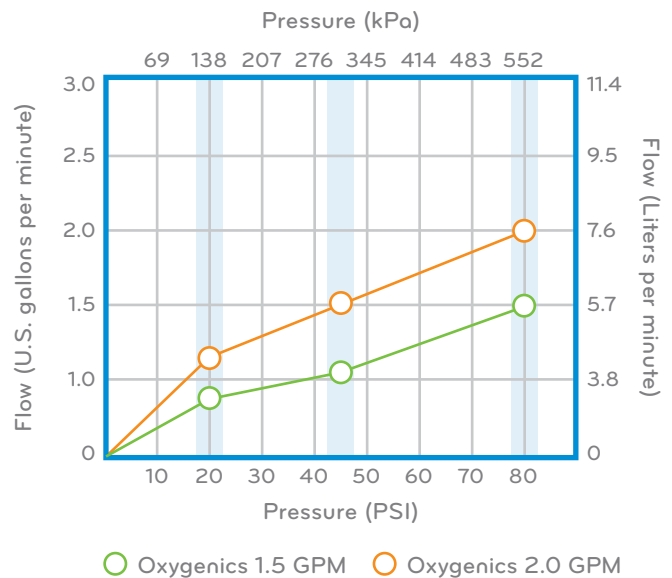

**"NEVER CLOG!" Warranty**

Limited lifetime performance warranty against failure or clogging.

